

**Industrial fluid
care and filter**

Your daily routine: The attrition



Cutting fluid

Tasks:

- Cooling
- Greasing
- Cleaning
- Rinsing
- Corrosion control

Challenges:

- Increased tool wear
- Staff shortages due to sickness
- Forming of bacteria and fungus
- High maintenance costs

Targets:

- Increase speed of operation
- Increase surface quality
- Protection of tools
- Decreasing operating costs

VITO

Your solution - The VITO product line



The VITO product line supports you with your coolant lubricant management. VITO cleans your coolant lubricant, oil and watery solution and prolongs the performance. Start improving quality, reduce costs and save time with the mobile filtration system.

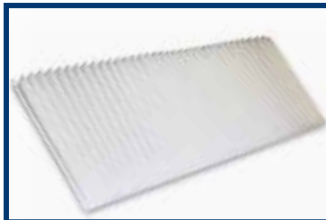

Before filtration



After filtration



VITO 60

Suitable for industrial basins up to 500l

made
in
Germany



VITO 90

Suitable for all industrial basins

VITO - The filtration process

VITO removes chips and solids from your cutting fluid in only a few minutes. The illustration below clarifies the pressure flow filtration of VITO. The vortex creates a strong suction of particles and cutting fluid.

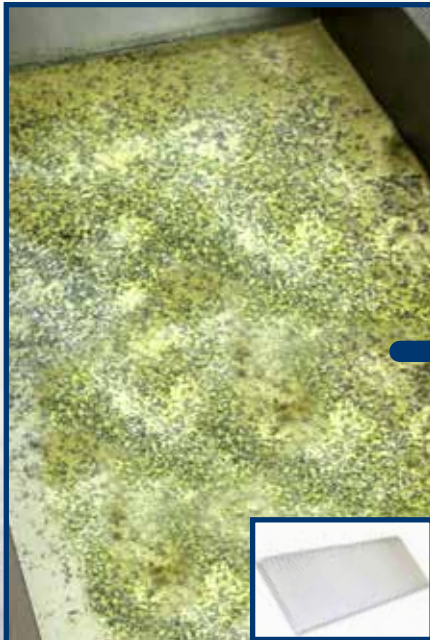

**Industrial basin
before filtration**



VITO in use



**Industrial basin
after filtration**

VITO - Machine & filter

The VITO removes particles up to 5µm. The patented mechanical filtration reduces forming of bacteria and fungus in a couple of minutes.

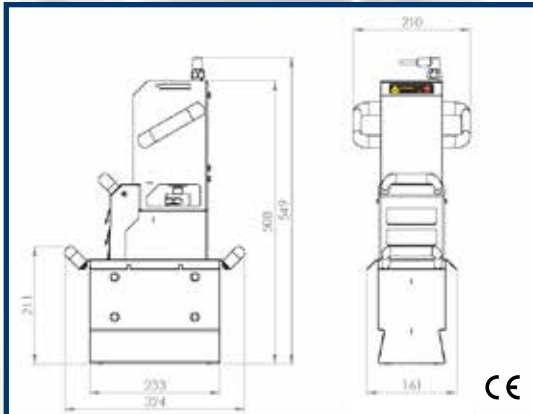

made
in
Germany



The machine:

- Pressure-flow-filtration
- Filtration power up to 60-95l per minute
- Cycle time 4,5min (pulsed operation available)

The filter:

- Polyester cellulose filter
- Surface of the filter 0,25 m²
- Filtration grade 20 µm nominal / 5 µm effective
- Grammage of 100 g/m²

VITO 60 & 90 - Technical details



	Filtration capacity	Filtration efficiency	Dirt hold capacity	Cycle time	Suction depth	Weight	Temperature medium	Housing	Particle filter	Max. power
VITO 60	bis zu 60l/min	5 µm effektiv 20 µm nominal	1,4l	4,5 min	~ 20 cm	6,3 kg	max. 200°C	Stainless steel 1.4301	Polyester cellulose	300 W
VITO 90	bis zu 95l/min	5 µm effektiv 20 µm nominal	2,5l	4,5 min	~ 35 cm	7,7 kg	max. 200°C	Stainless steel 1.4301	Polyester cellulose	400 W

VITO accessoires



Clip on frame

Attach VITO directly in the tank
Customisable for all industrial tanks.



Particle filter

Bundle size: 1 box (50 pcs.)
Filter area: 0.25m²
Material: Polyester cellulose
Filtration efficiency:
nom. 20 µm/eff. 5 µm



Holding brackets

Keep VITO in secure standing.
Customisable for all industrial tanks.
Reduce vibration.



Data reader

Readout the user information
like programmable cycle time,
total running time,
total number of cycles
and max. temperature.



The VITO product line

- 🔹 Ensure the quality of your cutting fluid
- 🔹 Save money
- 🔹 Reduce unnessecary maintenance time
- 🔹 Easy handling



Manufacturer:
VITO AG
Eltastr.6, 78532 Tuttlingen
T: +49 (0) 7461 / 1508050
F: +49 (0) 7461 / 1508051
info@vito-industrial.com
www.vito-industrial.com

VITO® is a registered trademark of
VITO AG, Germany.
V 5.17

Follow us on

