

# TRAILER AXLES AND SUSPENSIONS

**assali**  
**STEFEN**





# RIGID AXLES DRUM BRAKE



## TA series

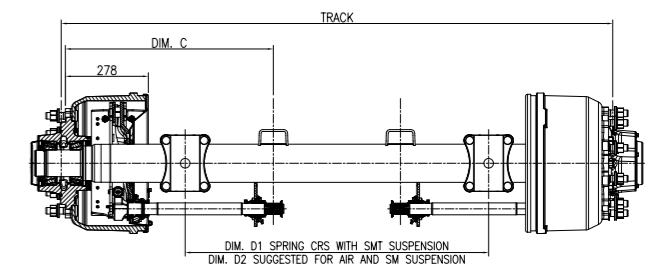

Q plus (420x180) BRAKE						
Type	Track	Wheel	C	D1	D2	Cap.
TAQ#225	1820	twin	760	1020	1000	10t
	1920	twin	760	1120	1100	10t
	1950	twin	760	1150	1130	10t
	2045	single	760	1275	1200	10t
	2068	single	760	1300	1225	10t
	2128	single	760	1325	1305	10t
TAQ#250	1820	twin	760	1020	1000	11t
	1920	twin	760	1120	1100	11t
	1950	twin	760	1150	1130	11t
	2045	single	760	1275	1200	11t
	2068	single	760	1300	1225	11t
	2128	single	760	1325	1305	11t

## TM series

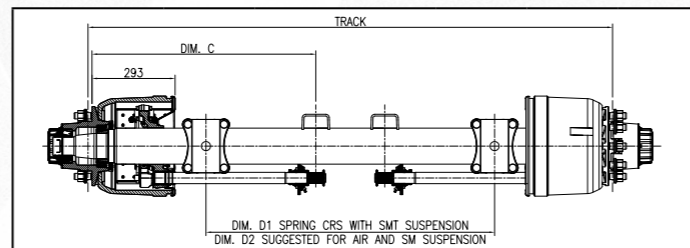

AC / AS (310x190) BRAKE						
Type	Track	Wheel	C	D1	D2	Cap.
TMA#225 TMAS#225	1820	twin	790	990	960	10,5t
	1880	twin	790	1050	1020	10,5t
	1920	twin	790	1090	1060	10,5t
	1950	twin	790	1120	1090	10,5t
	2000	single	790	1170	1140	10,5t
	2045	single	790	1215	1185	10,5t
	2100	single	790	1270	1240	10,5t
	2128	single	790	1298	1268	10,5t
TMAS#250	1820	twin	790	990	960	12t
	1920	twin	790	1090	1060	12t
	2000	single	790	1170	1140	12t
	2045	single	790	1215	1185	12t

## LM series

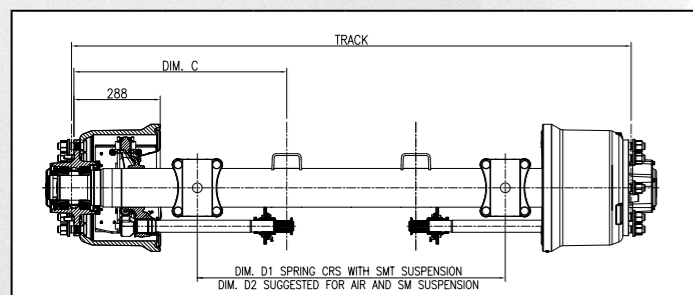

B (350x200) BRAKE						
Type	Track	Wheel	C	D1	D2	Cap.
LMB#900	1850	twin	778	1030	1010	9t
	2045	single	778	1225	1205	9t
LMB#930	1880	twin	778	1060	1040	9,3t
	1920	twin	778	1100	1080	9,3t

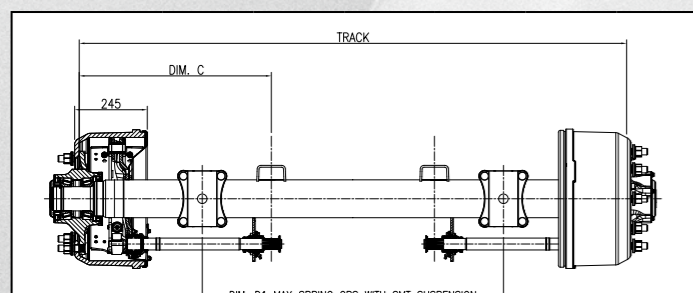

Q plus (420x180) BRAKE						
Type	Track	Wheel	C	D1	D2	Cap.
LMQ#900	2045	single	730	1300	1260	9t
	2100	single	730	1355	1315	9t
	2145	single	730	1400	1360	9t
LMQ#930	2045	single	730	1300	1260	9,3t
	2100	single	730	1355	1315	9,3t
	2145	single	730	1400	1360	9,3t

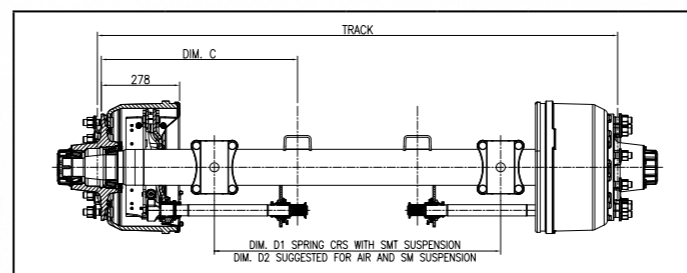

Q plus (420x180) BRAKE						
Type	Track	Wheel	C	D1	D2	Cap.
TMQ#225 *	1820	twin	760	1020	1000	10t
	1920	twin	760	1120	1100	10t
	1950	twin	760	1150	1130	10t
	2045	single	760	1275	1200	10t
	2068	single	760	1300	1225	10t
	2128	single	760	1325	1305	10t
TMQ#250	1820	twin	760	1020	1000	11t
	1920	twin	760	1120	1100	11t
	1950	twin	760	1150	1130	11t
	2045	single	760	1275	1200	11t
	2068	single	760	1300	1225	11t
	2128	single	760	1325	1305	11t

\* Also available with offset hub

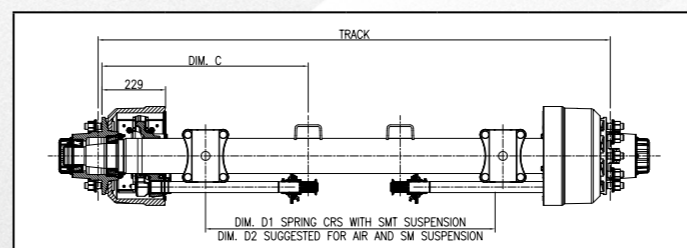

S / SC (310x160) BRAKE						
Type	Track	Wheel	C	D1	D2	Cap.
TMS#225 TMSC#225	1920	twin	745	1120	1100	10t
	2000	twin	745	1200	1180	10t
	2100	single	745	1300	1280	10t

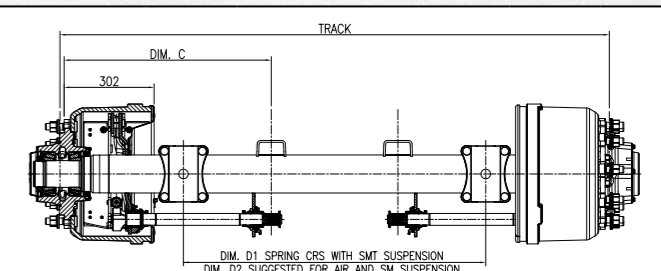

Z / ZS (420x220) BRAKE						
Type	Track	Wheel	C	D1	D2	Cap.
TAZ#225 TAZS#225	1820	twin	760	1020	1000	10t
	1850	twin	760	1050	1020	10t
	1880	twin	760	1080	1050	10t
	2045	single	760	1250	1200	10t
TAZ#250 TAZS#250	1820	twin	760	1020	1000	12t
	1850	twin	760	1050	1020	12t
	1920	twin	760	1090	1060	12t
	2045	single	760	1250	1200	12t
TAZ#300 TAZS#300	1820	twin	760	1020	1000	14,2t
	1850	twin	760	1050	1020	14,2t

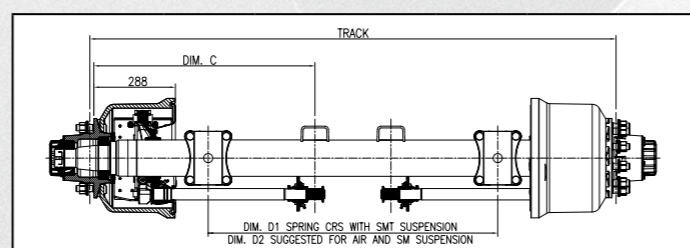

B / BS (350x200) BRAKE						
Type	Track	Wheel	C	D1	D2	Cap.
TMB#225 * TMBS#225	1820	twin	778	1000	980	10,5t
	1850	twin	778	1030	1010	10,5t
	1880	twin	778	1060	1040	10,5t
	1920	twin	778	1100	1080	10,5t
	2045	single	778	1225	1205	10,5t
	2128	single	778	1305	1285	10,5t
TMBS#250	1850	twin	778	1030	1010	12t
	1880	twin	778	1060	1040	12t
	1920	twin	778	1100	1080	12t
	1950	twin	778	1130	1100	12t
	2045	single	778	1225	1205	12t
	2128	single	778	1305	1285	12t

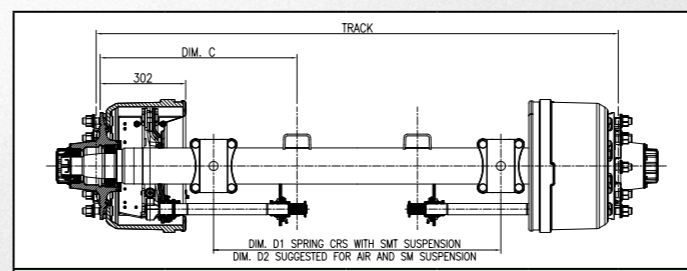

Z / ZS (420x220) BRAKE						
Type	Track	Wheel	C	D1	D2	Cap.
TMZ#225 TMZS#225	1820	twin	760	1020	1000	10t
	1850	twin	760	1050	1020	10t
	1880	twin	760	1080	1050	10t
	1920	twin	760	1120	1080	10t
	1950	twin	760	1150	1120	10t
	2045	single	760	1250	1200	10t
TMZ#250 TMZS#250	1820	twin	760	1020	1000	12t
	1850	twin	760	1050	1020	12t
	1880	twin	760	1080	1050	12t
	1920	twin	760	1120	1080	12t
	1950	twin	760	1150	1120	12t
	2045	single	760	1250	1200	12t

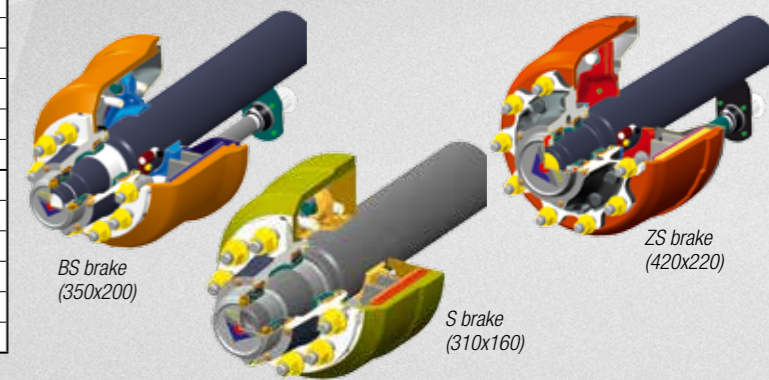

\* Also available with offset hub



# RIGID AXLES DISC BRAKE

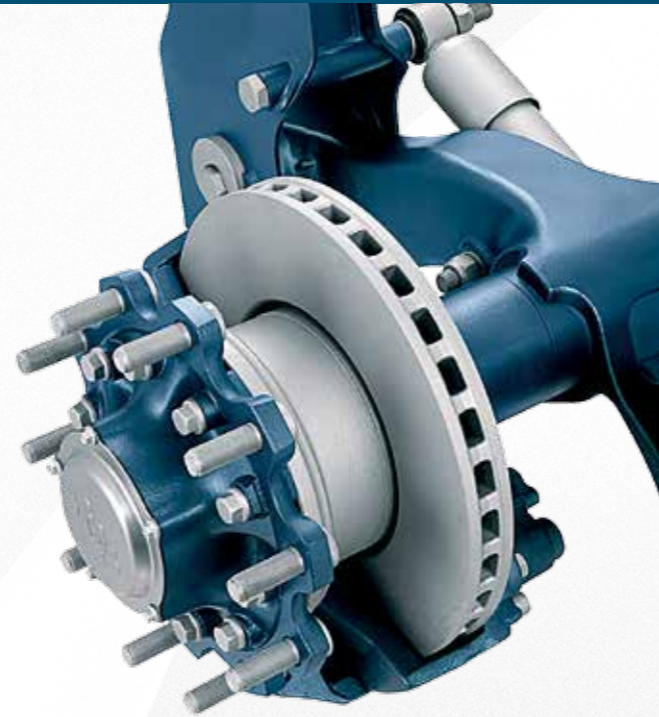

## LM series

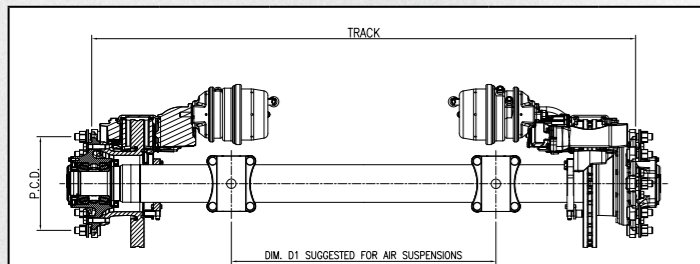

Elsa2 (E)					
Type	Track	Wheel	P.C.D.	D1	Cap.
LME#900	2045	single	10x335	1300	9t
	2100	single	10x335	1355	9t
	2145	single	10x335	1400	9t
LME#930	2045	single	10x335	1300	9,3t
	2100	single	10x335	1355	9,3t
	2145	single	10x335	1400	9,3t

Elsa225L (J)					
Type	Track	Wheel	P.C.D.	D1	Cap.
LMJ#900	2045	single	10x335	1300	9t
	2100	single	10x335	1355	9t
	2145	single	10x335	1400	9t
LMJ#930	2045	single	10x335	1300	9,3t
	2100	single	10x335	1355	9,3t
	2145	single	10x335	1400	9,3t

Elsa195LE (K)					
Type	Track	Wheel	P.C.D.	D1	Cap.
LMK#900	2045	single	10x335	1300	9t
	2100	single	10x335	1355	9t
	2145	single	10x335	1400	9t
LMK#930	2045	single	10x335	1300	9,3t
	2100	single	10x335	1355	9,3t
	2145	single	10x335	1400	9,3t

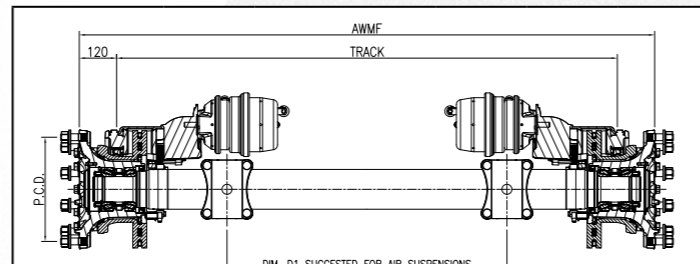

Elsa2 (E) 120 offset hub						
Type	AWMF	Track	Wheel	P.C.D.	D1	Cap.
LME0#900	2285	2045	single	10x335	1300	9t
	2340	2100	single	10x335	1355	9t
	2385	2145	single	10x335	1400	9t
LME0#930	2285	2045	single	10x335	1300	9,3t
	2340	2100	single	10x335	1355	9,3t
	2385	2145	single	10x335	1400	9,3t

Elsa225L (J) 120 offset hub						
Type	AWMF	Track	Wheel	P.C.D.	D1	Cap.
LMJ0#900	2285	2045	single	10x335	1300	9t
	2340	2100	single	10x335	1355	9t
	2385	2145	single	10x335	1400	9t
LMJ0#930	2285	2045	single	10x335	1300	9,3t
	2340	2100	single	10x335	1355	9,3t
	2385	2145	single	10x335	1400	9,3t

Elsa195LE (K) 120 offset hub						
Type	AWMF	Track	Wheel	P.C.D.	D1	Cap.
LMK0#900	2285	2045	single	10x335	1300	9t
	2340	2100	single	10x335	1355	9t
	2385	2145	single	10x335	1400	9t
LMK0#930	2285	2045	single	10x335	1300	9,3t
	2340	2100	single	10x335	1355	9,3t
	2385	2145	single	10x335	1400	9,3t

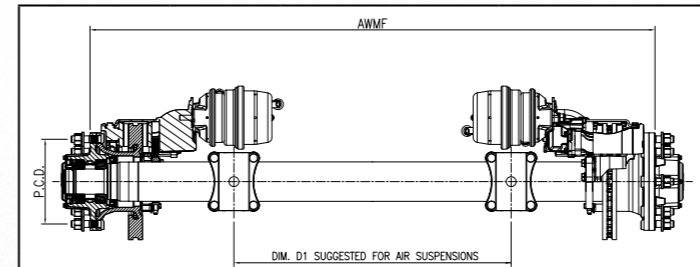

Elsa195LE (K)					
Type	AWMF	Wheel	P.C.D.	D1	Cap.
LMK#900	1850	twin	8x275	980	9t
	1880	twin	8x275	1010	9t
	2030	single	8x275	1220	9t
	2045	single	8x275	1230	9t
	2130	single	8x275	1320	9t
LMK#930	1850	twin	8x275	980	9,3t
	1880	twin	8x275	1010	9,3t
	2030	single	8x275	1220	9,3t
	2045	single	8x275	1230	9,3t
	2130	single	8x275	1320	9,3t

## TM series

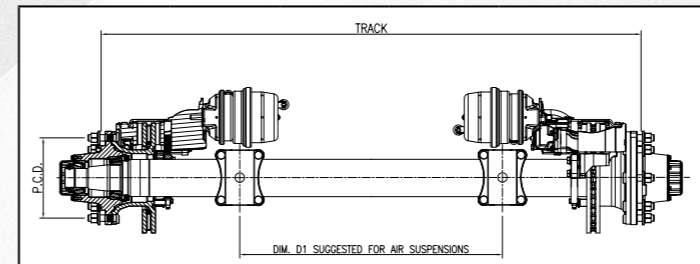

Elsa195LE (K)					
Type	Track	Wheel	P.C.D.	D1	Cap.
TMK#225	1820	twin	8x275	920	10t
	1850	twin	8x275	950	10t
	1880	twin	8x275	980	10t
	1920	twin	8x275	1020	10t
	1950	twin	8x275	1050	10t
	2000	single	8x275	1100	10t
	2045	single	8x275	1145	10t
	2110	single	8x275	1210	10t
	2128	single	8x275	1228	10t
	TMK#250	1820	twin	8x275	920
1850		twin	8x275	950	11t
1880		twin	8x275	980	11t
1920		twin	8x275	1020	11t
1950		twin	8x275	1050	11t
2000		single	8x275	1100	11t
2045		single	8x275	1145	11t
2110		single	8x275	1210	11t
2128		single	8x275	1228	11t

## TA series

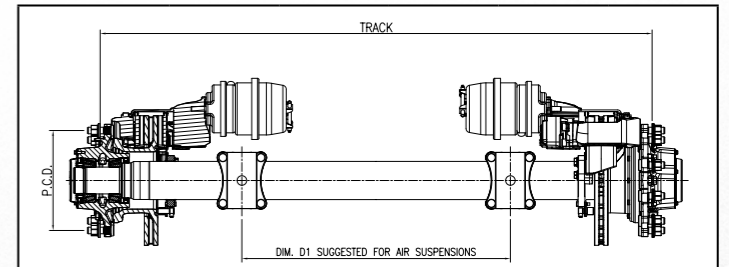

Elsa2 (E)					
Type	Track	Wheel	P.C.D.	D1	Cap.
TAE#225	1820	twin	10x335	920	10t
	1850	twin	10x335	950	10t
	1880	twin	10x335	980	10t
	1920	twin	10x335	1020	10t
	1950	twin	10x335	1050	10t
	2045	single	10x335	1100	10t
	2088	single	10x335	1188	10t
	2128	single	10x335	1228	10t
	TAE#250	1820	twin	10x335	920
1850		twin	10x335	950	12t
1880		twin	10x335	980	12t
1920		twin	10x335	1020	12t
1950		twin	10x335	1050	12t
2045		single	10x335	1100	12t
2088		single	10x335	1188	12t
2128		single	10x335	1228	12t
TAE#300		1850	twin	10x335	950
	2045	single	10x335	1100	13t

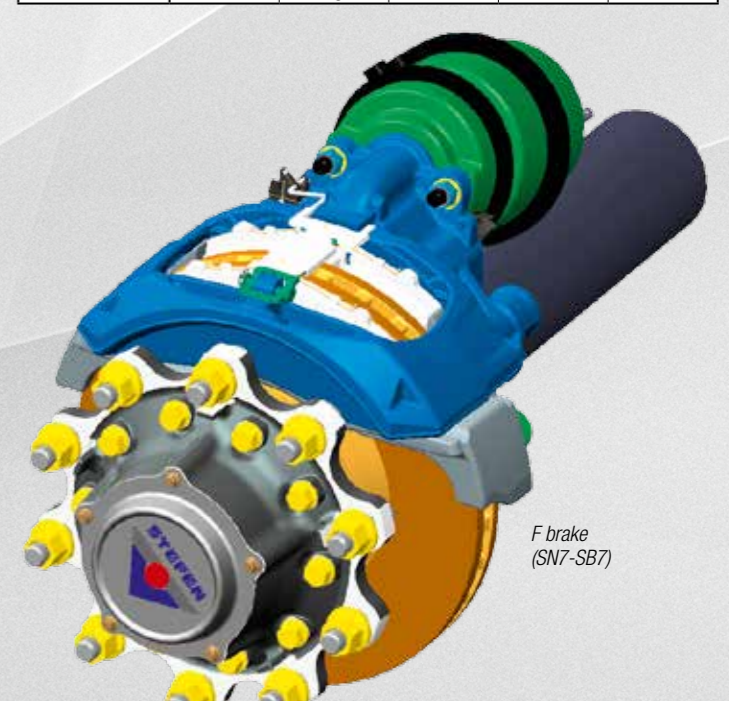

F brake (SN7-SB7)



# SELF STEERING, COMMAND STEER AND SPECIAL RIGID AXLES

## Self-steering axle

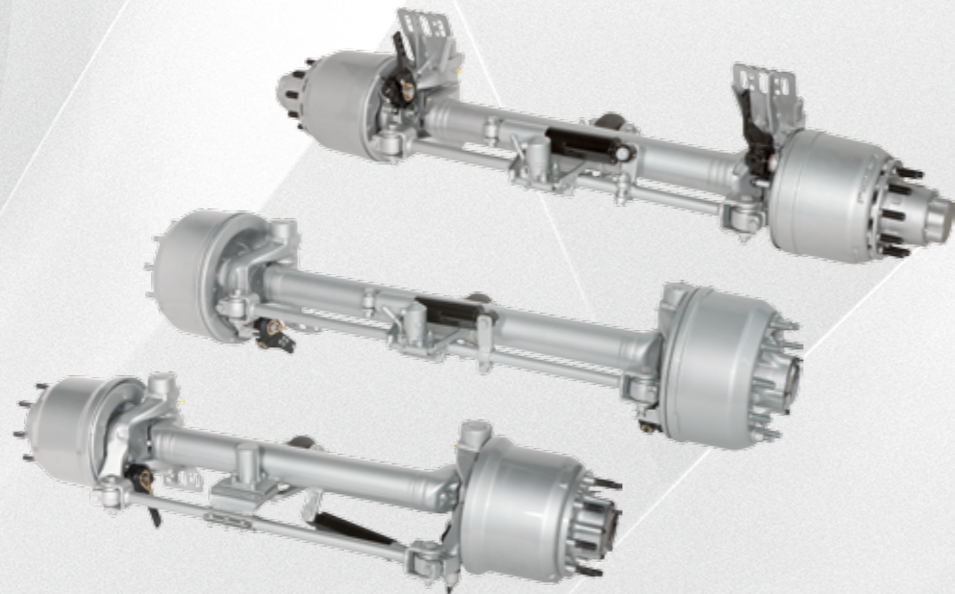
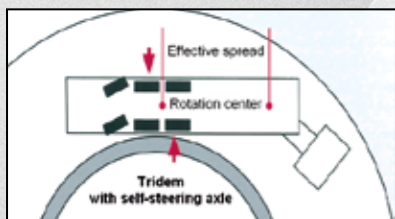
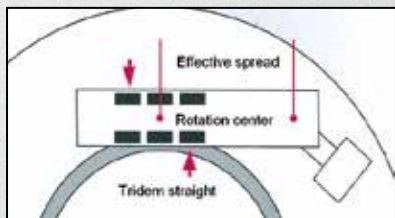
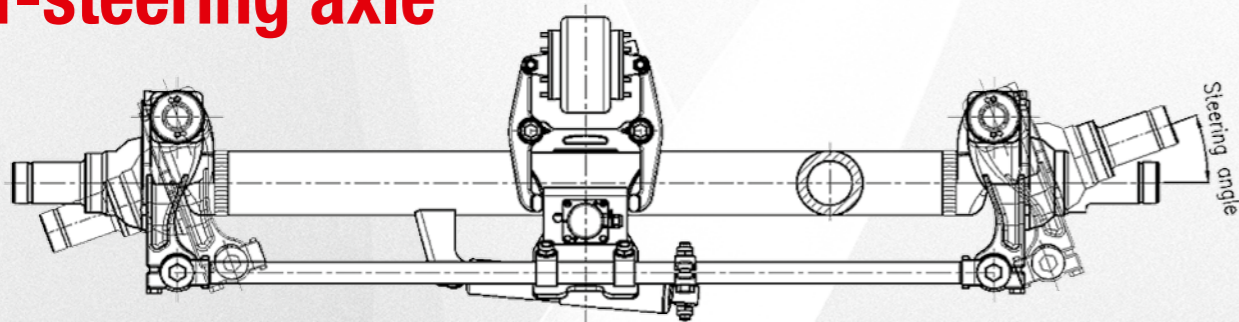

**ECO-FRIENDLY**

- IMPROVES TYRE LIFE
- IMPROVES TRAILER MANEUVERABILITY
- REDUCES FUEL CONSUMPTION
- REDUCES TYRE WEAR

## Command steer axle

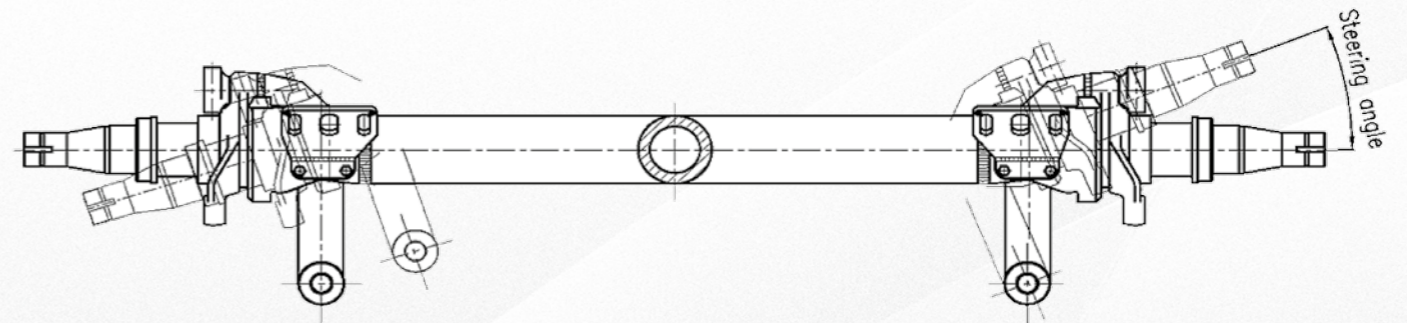

- FOR SPECIAL APPLICATIONS
- THE AXLES ARE MECHANICALLY STEERED

## Special axles

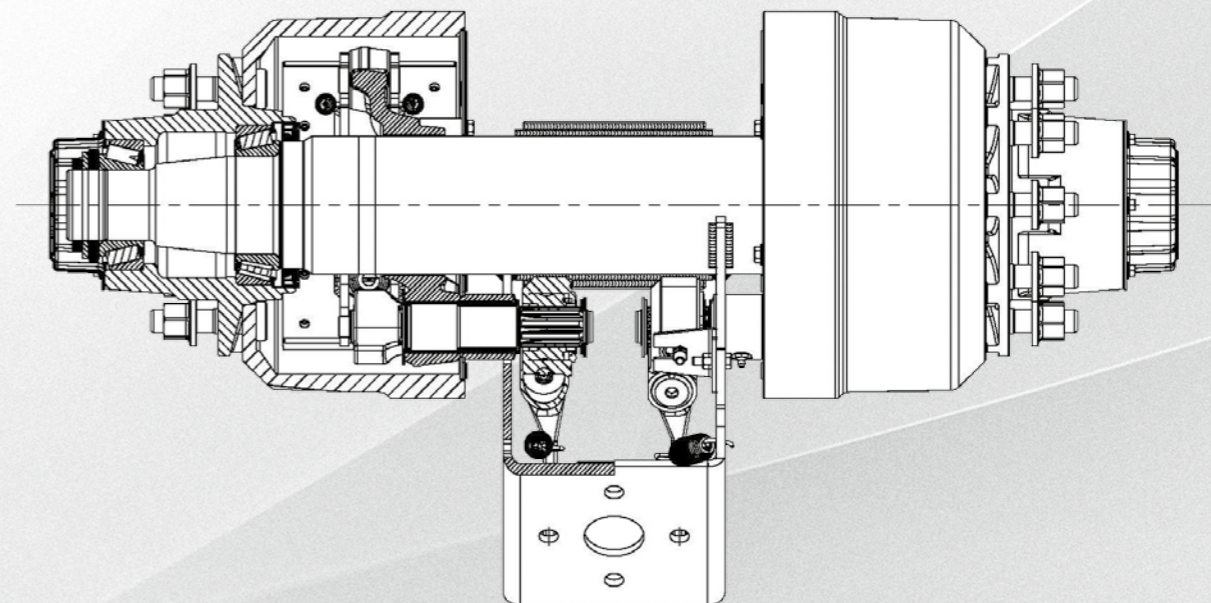

- SPECIAL CAPACITY UP TO 30 TON
- TRACK LENGTH FROM 900 TO 4500 mm
- SWIVEL AXLES





# AIR SUSPENSIONS

## FLEXAIR series

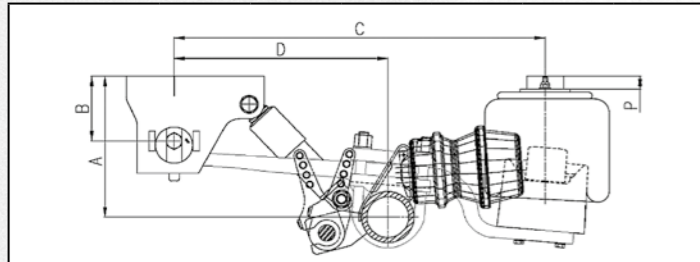

Type	Cap.	A (R H)	B	C	D	P
FLX9NB#	9t	310	120	895	516	0
	9t	325	135	895	516	0
	9t	350	160	895	516	25
	9t	375	185	895	516	50
FLX9NBE#	9t	375	220	895	526	0
	9t	400	245	895	526	25
	9t	425	270	895	526	50
	9t	450	295	895	526	75
9t	475	320	895	526	100	

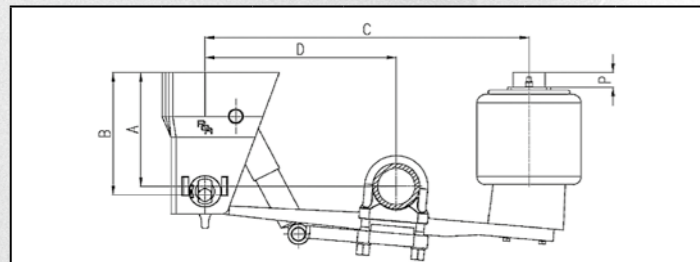

Type	Cap.	A (R H)	B	C	D	P
FP9#	9t	250	275	905	534	8
	9t	275	300	905	534	25
	9t	300	325	905	534	50

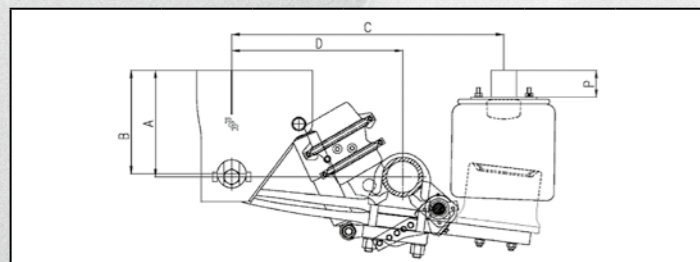

Type	Cap.	A (R H)	B	C	D	P
FLX11#	11t	250	250	850	534	6
	11t	275	275	850	534	25
	11t	300	300	850	534	50
	11t	325	325	850	534	75
	11t	350	350	850	534	100
	11t	375	375	850	534	125
	11t	400	400	850	534	150
	11t	425	425	850	534	175
11t	450	450	850	534	200	

## CS series European type

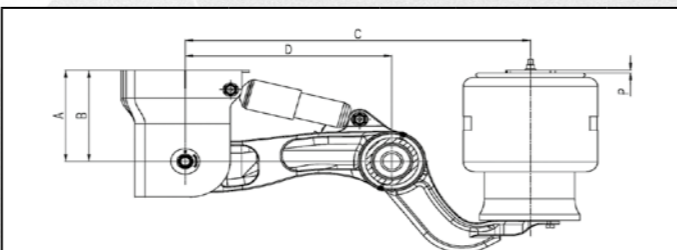

Type	Cap.	A (R H)	B	C	D	P
CS9eL#	9t	225 - 275	250	835	500	0
	9t	275 - 325	300	835	500	50
	9t	325 - 375	350	835	500	100

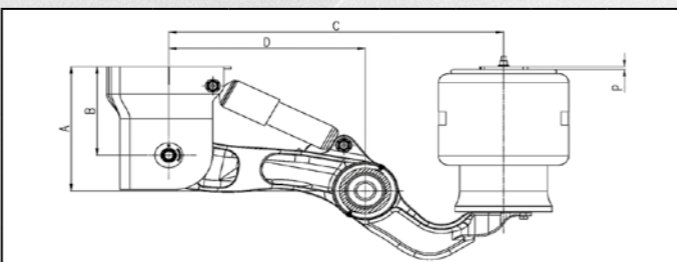

Type	Cap.	A (R H)	B	C	D	P
CS9eT#	9t	325 - 375	250	835	490	0
	9t	375 - 425	300	835	490	50
	9t	425 - 475	350	835	490	100
	9t	475 - 500	375	835	490	125

## International type

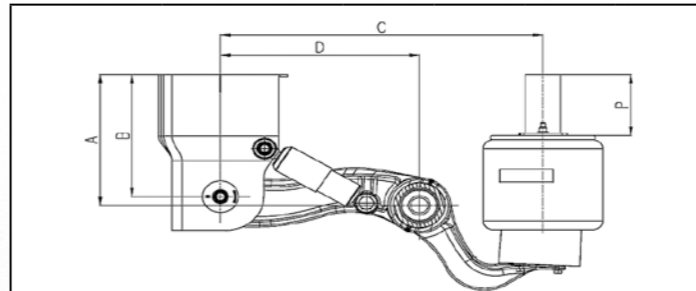

Type	Cap.	A (R H)	B	C	D	P
CS9iL#	9t	200	175	810	499	8
	9t	225	200	810	499	25
	9t	250	225	810	499	50
	9t	275	250	810	499	75
	9t	300	275	810	499	100
	9t	325	300	810	499	125
	9t	350	325	810	499	150
	9t	375	350	810	499	175

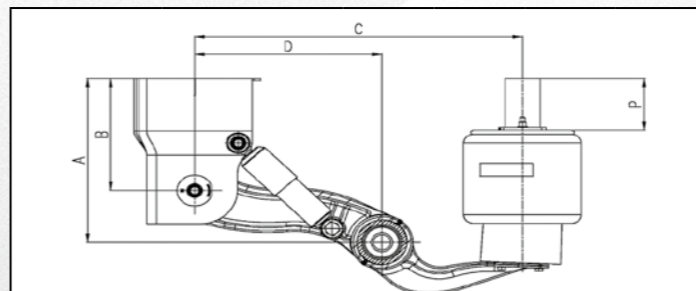

Type	Cap.	A (R H)	B	C	D	P
CS9iT#	9t	325	175	835	477	8
	9t	350	200	835	477	25
	9t	375	225	835	477	50
	9t	400	250	835	477	75
	9t	425	275	835	477	100
	9t	450	300	835	477	125
	9t	475	325	835	477	150
	9t	500	350	835	477	175

## STEF AIR series

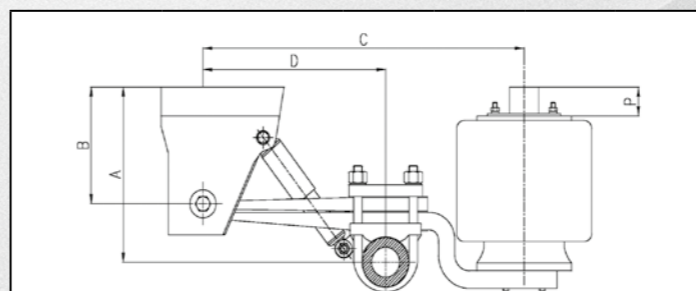

Type	Cap.	A (R H)	B	C	D	P
STF12#	12t	375	225	880	500	6
	12t	400	250	880	500	6
	12t	425	275	880	500	25
	12t	450	300	880	500	50
	12t	475	325	880	500	75

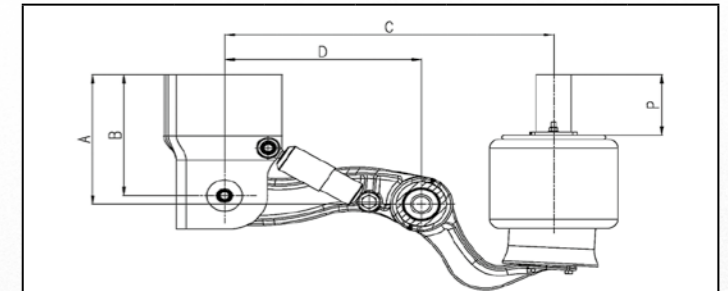

Type	Cap.	A (R H)	B	C	D	P
CS10iL#	10,5t	200	175	835	499	8
	10,5t	225	200	835	499	25
	10,5t	250	225	835	499	50
	10,5t	275	250	835	499	75
	10,5t	300	275	835	499	100
	10,5t	325	300	835	499	125
	10,5t	350	325	835	499	150
	10,5t	375	350	835	499	175

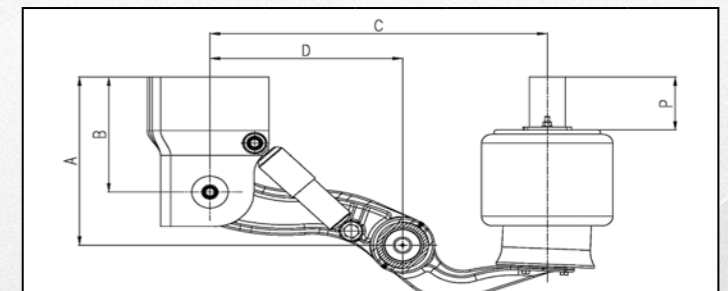

Type	Cap.	A (R H)	B	C	D	P
CS10iT#	10,5t	325	175	835	499	8
	10,5t	350	200	835	499	25
	10,5t	375	225	835	499	50
	10,5t	400	250	835	499	75
	10,5t	425	275	835	499	100
	10,5t	450	300	835	499	125
	10,5t	475	325	835	499	150
	10,5t	500	350	835	499	175

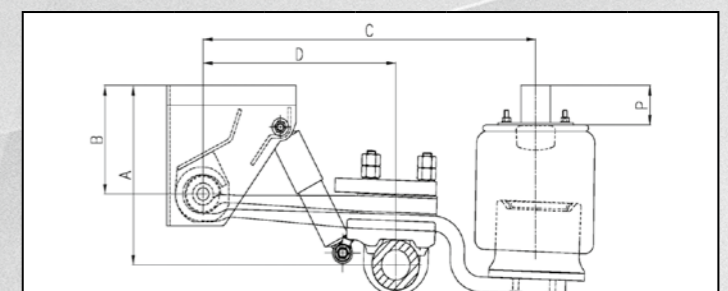

Type	Cap.	A (R H)	B	C	D	P
STF14#	13,5t	400	225	903	523	50
	13,5t	425	250	903	523	75
	13,5t	450	275	903	523	100
	13,5t	475	300	903	523	125
	13,5t	500	325	903	523	150



# MECHANICAL SUSPENSIONS



## SMT series

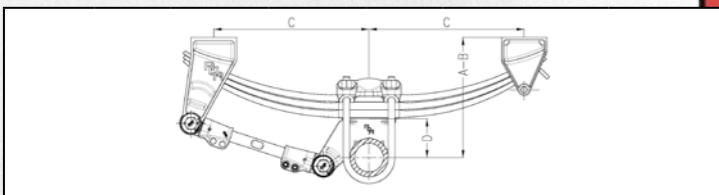
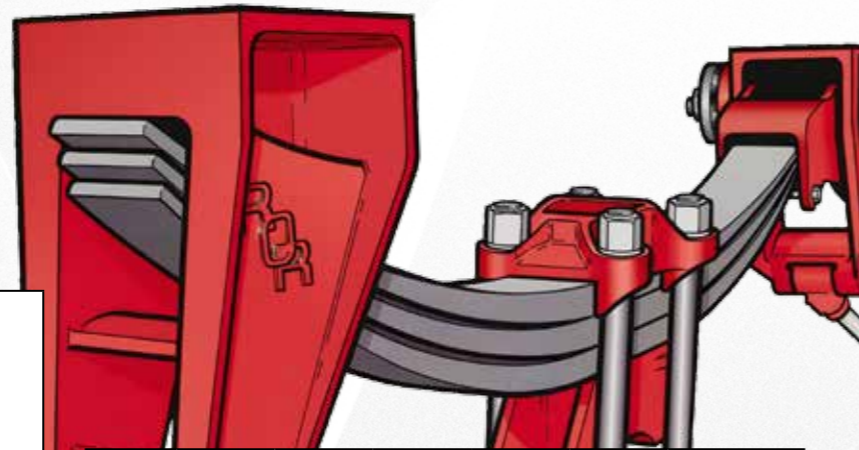

### SINGLE

Type	Cap.	A (unladen)	B (laden)	C	D (*)	No. of leaves	Spring part No.
SMT#	8t	381	354	413	68	3	21215420
	10t	400	353	518	68	3	21221244
	12t	412	362	518	68	4	21220913
	12t	450	402	518	68	12	21025427

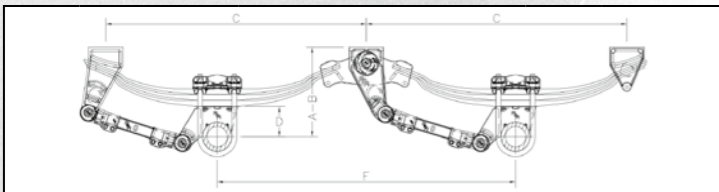

### TANDEM

Type	Cap.	A (unladen)	B (laden)	C	F	D (*)	No. of leaves	Spring part No.
SMT#	16t	381	354	980	1145	68	3	21215420
	20t	400	353	1194	1360	68	3	21221244
	24t	412	362	1194	1360	68	4	21220913
	24t	450	402	1194	1360	68	12	21025427

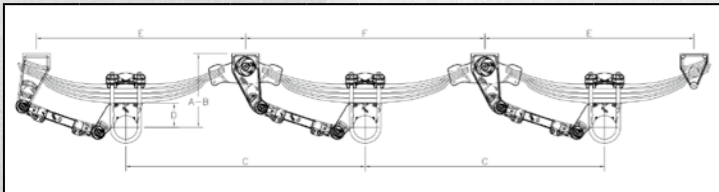

### TRI AXLE

Type	Cap.	A (unladen)	B (laden)	C	E	F	D (*)	No. of leaves	Spring part No.
SMT#	30t	400	353	1360	1194	1360	68	3	21221244 & 21221245
	36t	412	362	1360	1194	1360	68	4	21220913 & 21221509
	36t	450	402	1360	1194	1360	68	12	21025427 & 2102467

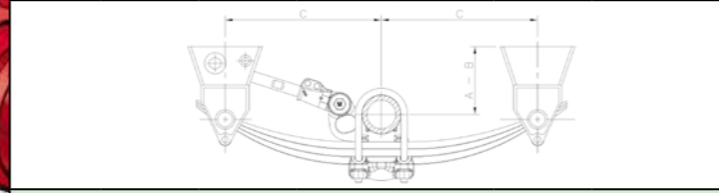

### SINGLE UNDERSLUNG

Type	Cap.	A (unladen)	B (laden)	C	No. of leaves	Spring part No.
SMT#	8t	381	354	413	3	21215420
	12t	450	402	518	12	21025427

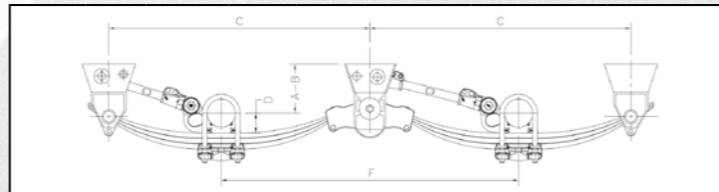

### TANDEM UNDERSLUNG

Type	Cap.	A (unladen)	B (laden)	C	F	D (*)	No. of leaves	Spring part No.
SMT#	20t	224	176	1194	1360	26	3	21221244
	24t	224	176	1194	1360	26	4	21220913

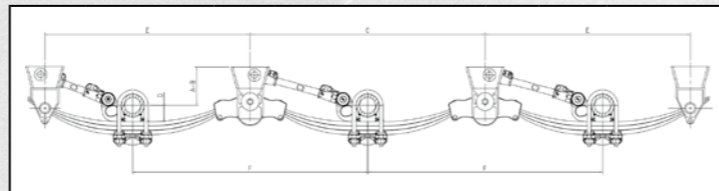

### TRI AXLES UNDERSLUNG

Type	Cap.	A (unladen)	B (laden)	C	E	F	D (*)	No. of leaves	Spring part No.
SMT#	30t	224	187	1360	1194	1360	26	3	21221244 & 21221245
	36t	224	187	1360	1194	1360	26	4	21220913 & 21221509

## SM series

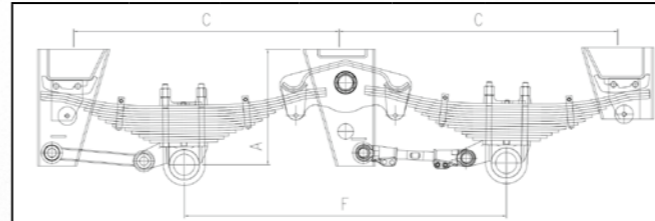

### TANDEM

Type	Cap.	A	C	F	No. of leaves
SM14#	28t	485	1175	1360	13
SM16#	32t	485	1175	1360	13

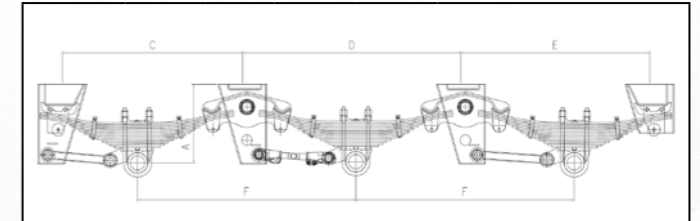

### TRI AXLES

Type	Cap.	A	C	D	F	No. of leaves
SM14#	42t	485	1175	1360	1360	13
SM16#	48t	485	1175	1360	1360	13

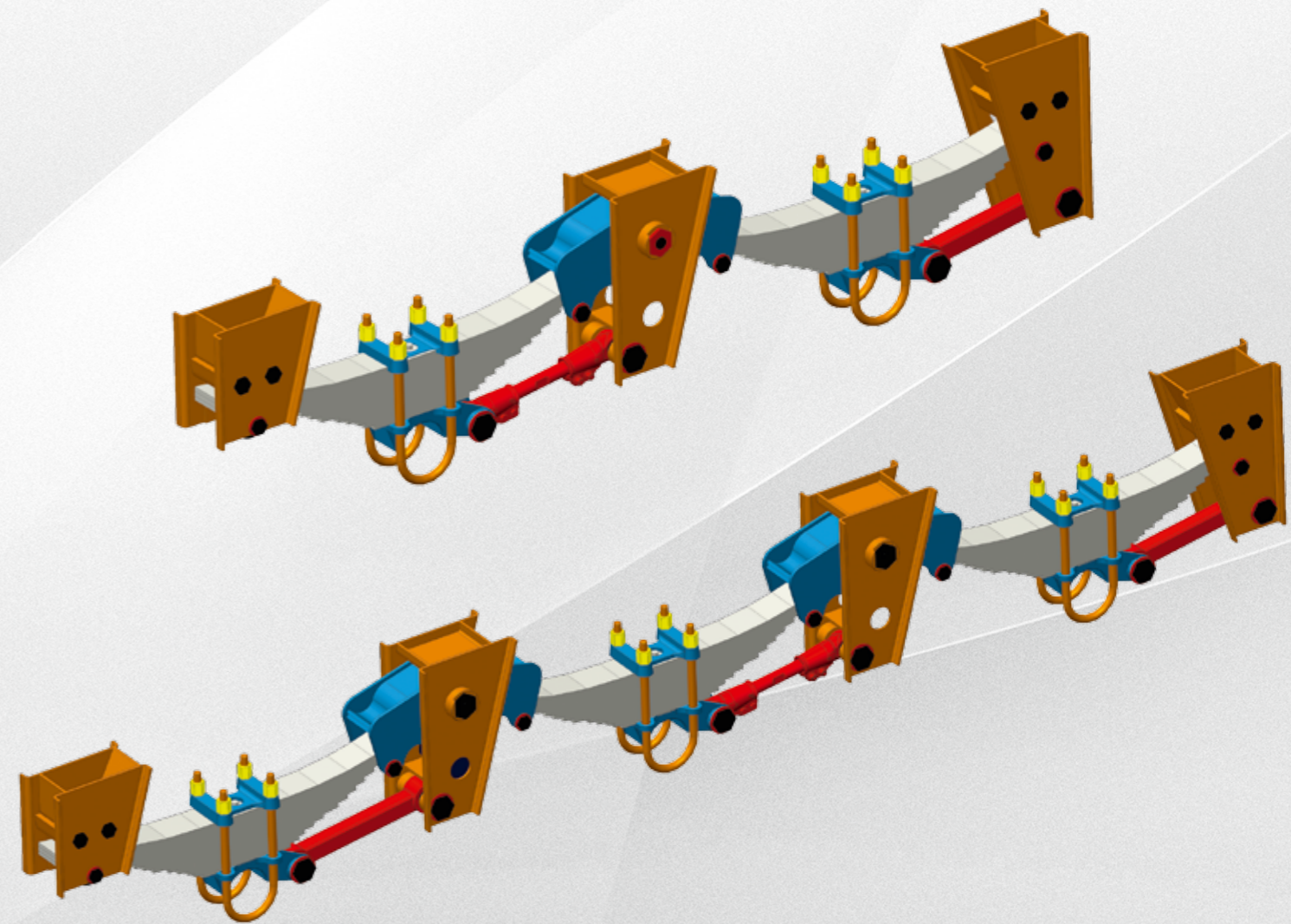



## **ASSALI STEFEN S.R.L.**

Viale Copernico, 1 - Loc. Campagnola - 37059 Zevio (Verona) Italy

Tel. +39 045 8731600 - Fax +39 045 8731602

[www.assalistefen.com](http://www.assalistefen.com) - [sales@assalistefen.com](mailto:sales@assalistefen.com)