

DDSB – Double diaphragm Spring brake actuator

DDSB consists of service brake chamber and a spring brake chamber. The air pressure applied into the service chamber is converted into mechanical output force. The spring chamber provides the mechanical braking force to park the vehicle. In addition, a mechanical release arrangement is provided in the unit to release the parking brake after brake failure. ProVia offers a cost attractive, high performance spring brake actuators for commercial vehicles.

About

- ProVia DDSB have an universal design to cover a wide range of OE applications
- Offers a significantly longer lifetime in terms of operating cycles and better corrosion resistance compared to many other budget actuators

Main Features

- 1 million lifecycles for service chamber, 200,000 cycles on park chamber
- 96 hours corrosion resistance
- Working temperature: -40 °C to +80 °C
- Maximum working temperature : 10 bar
- Crimp design on spring brake chamber for customer safety
- Delivered with yoke
- Lower leakage

Standards & Quality

- SAE standard
- Stroke length 2.5" / 63.5 mm

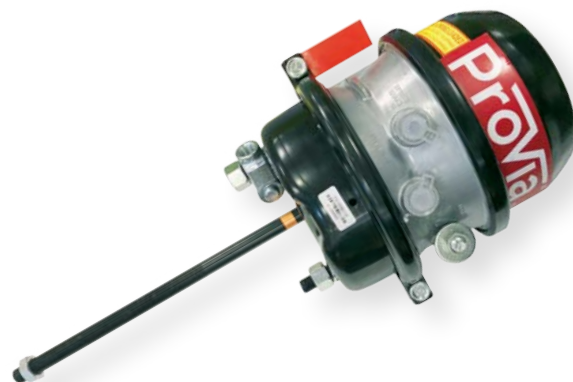

All fulfills the SAE standards

More operating cycles and universal application

The 'No compromise on safety' choice

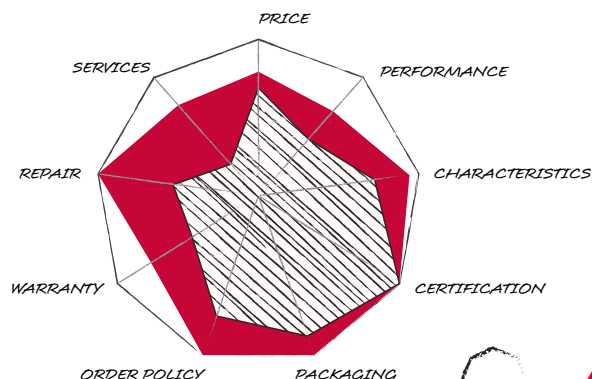

ProVia™

ProVia number	Size	Stroke					
			A - Length	B - Piggyback	C - Spring housing flange	E - Stud spacing	J - Push-rod length (without fork)
PRO 392 203 0	30/30	2.5" / 63.5 mm	9.10" / 231mm	5.9" / 150 mm	8.11" / 206 mm	4.75" / 120 mm	7.00" / 179 mm
PRO 392 204 0	30/30	2.5" / 63.5 mm	9.10" / 231mm	5.9" / 150 mm	8.11" / 206 mm	4.75" / 120 mm	7.00" / 179 mm
PRO 392 2010	30/30	2.5" / 63.5 mm	9.10" / 231mm	5.9" / 150 mm	8.11" / 206 mm	4.75" / 120 mm	7.90" / 200 mm
PRO 392 200 0	30/30	2.5" / 63.5 mm	9.10" / 231mm	5.9" / 150 mm	8.11" / 206 mm	4.75" / 120 mm	9.75" / 248 mm
PRO 392 202 0	24/30	2.5" / 63.5 mm	8.98" / 228 mm	5.5" / 140 mm	8.11" / 206 mm	4.75" / 120 mm	9.75" / 248 mm

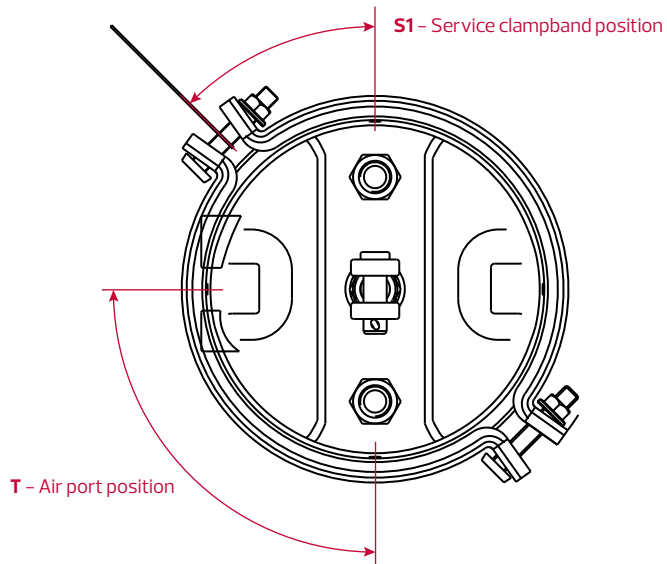

Dimensions (see drawing)

K - Push-rod length + fork (middle of yoke)	T - Air port position	S1 - Clampband position	U - Mounting bolt thread	V - Mounting bolt length	W - Push-rod thread	X - Air port thread
8.3" / 211mm	90°	50°	M16×1.5	1.46" / 37 mm	M16×1.5	NPT 3/8
8.3" / 211mm	90°	50°	M16×1.5	1.46" / 37 mm	M16×1.5	M16×1.5
9" / 230 mm	90°	45	5/8-11UNC	1.46" / 37 mm	5/8-18 UNF	3/8-18 NPTF
11.0" / 280 mm	90°	0°	5/8-11UNC	1.46" / 37 mm	5/8-18 UNF	3/8-18 NPTF
11.0" / 280 mm	90°	0°	5/8-11UNC	1.46" / 37 mm	5/8-18 UNF	3/8-18 NPTF

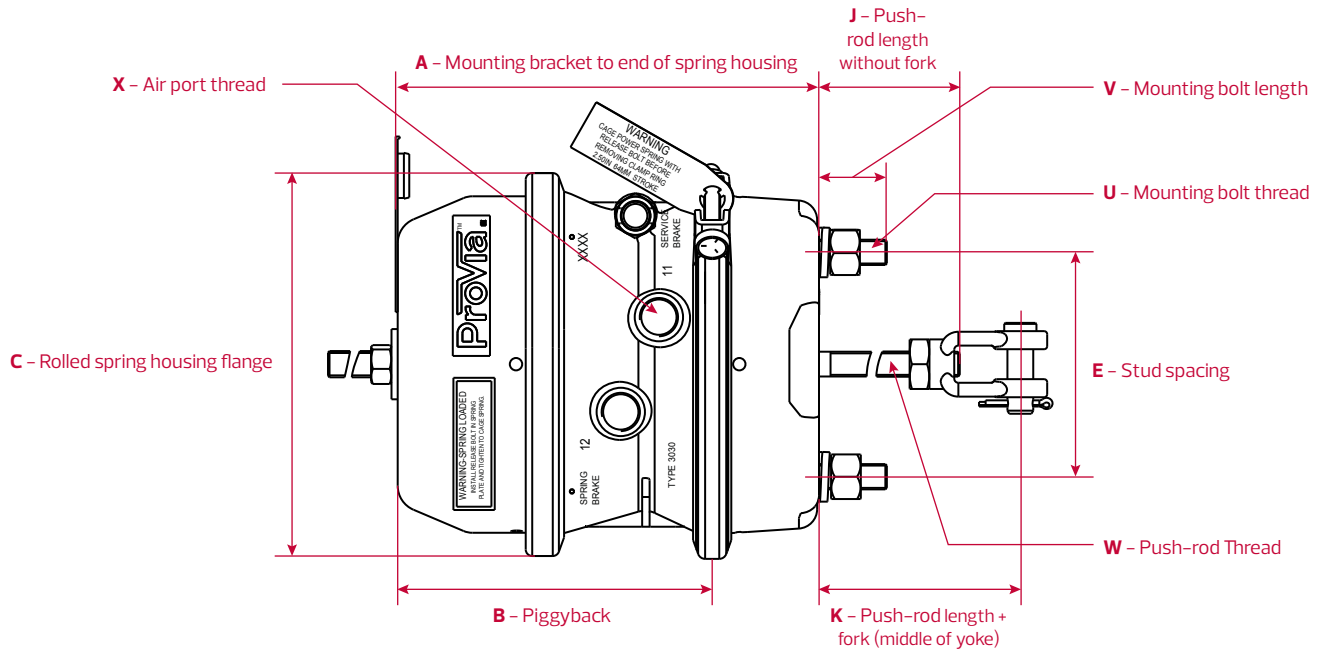

About ProVia

ProVia is a commercial vehicle budget spare parts brand that delivers reliable performance, with no frills, yet no compromise on quality or safety for trucks, buses, and trailers.

ProVia is available to distributors, workshops and fleet operators serving the commercial vehicle industry worldwide.

For more information, visit www.provia-auto.com

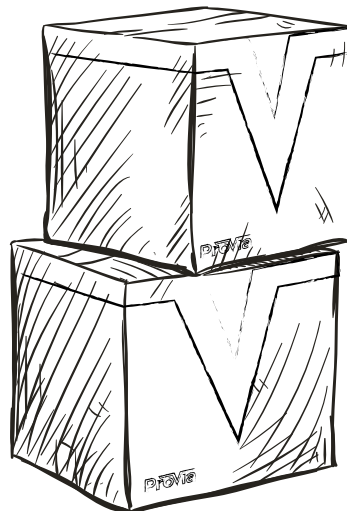

DISCLAIMER

The data or information contained in this document are intended for authorized ProVia distributors only, and shall not be passed to any third party.

The document is provided for informative purposes only, and the provision shall not be construed as a warranty or guarantee regarding the accuracy, adequacy, completeness, timeliness or usefulness of the data or information or the characteristics of a product.

WABCO shall not be held liable for errors or omissions in the data or information, or for any damage, including, without limitation, lost profits or consequential damages, relating in any way to the use of the data and information, except in case the respective damage is based on an event caused by willful intent or gross negligence.

